

PROPRIETARY AND CONFIDENTIAL

THE INFORMATION CONTAINED IN THIS DRAWING IS THE SOLE PROPERTY OF XLT Systems Pte Ltd. ANY REPRODUCTION IN PART OR AS A WHOLE WITHOUT THE WRITTEN PERMISSION OF XLT Systems Pte Ltd IS PROHIBITED.

PROJECT TITLE:

No	REVISION	DATE	NAME

DRAWN BY:  YEO 14/07/2023
 CHECKED BY:
 APPROVED BY:
 SCALE 1:5 SHEET : 1/3

CUSTOMER: --

EQUIPMENT / PROJECT NAME
POP-OUT BRACKET 2023_WPO-751
 PART NAME
ASSEMBLY DRAWING
 PART NUMBER
POPOUT BRACKET 2023 ASSY

MATERIAL
MS
 TREATMENT
BLACK POWDER COAT
 QTY
01

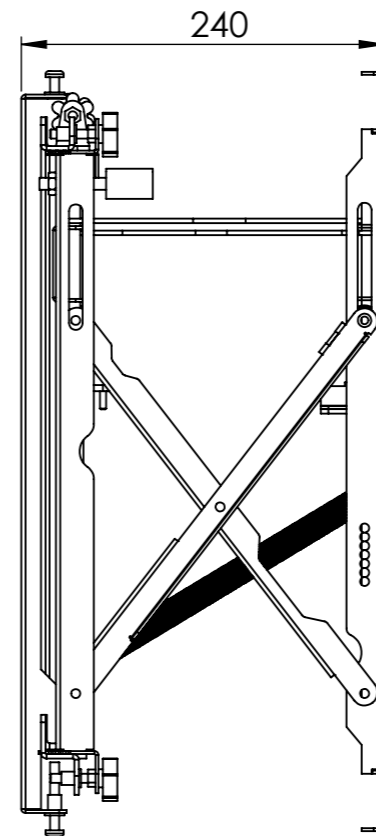
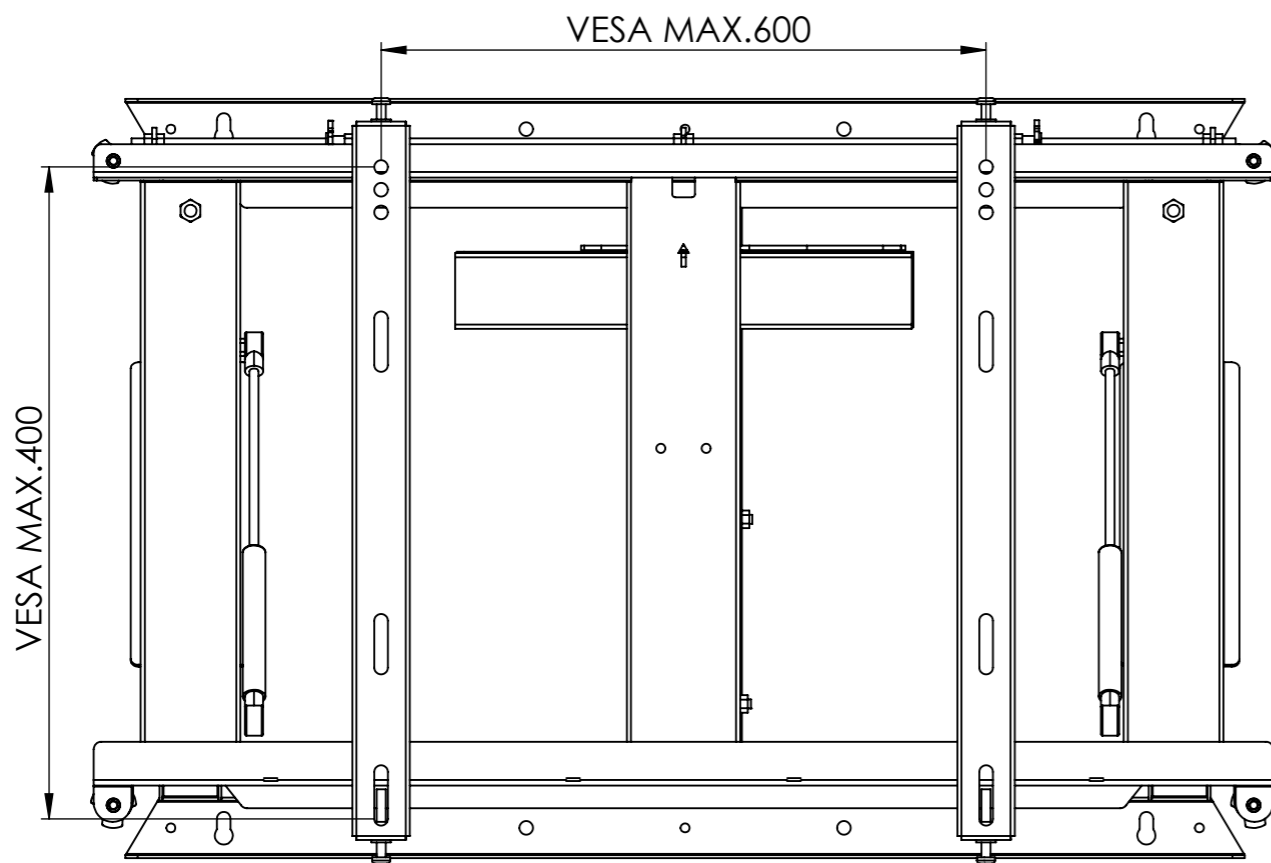
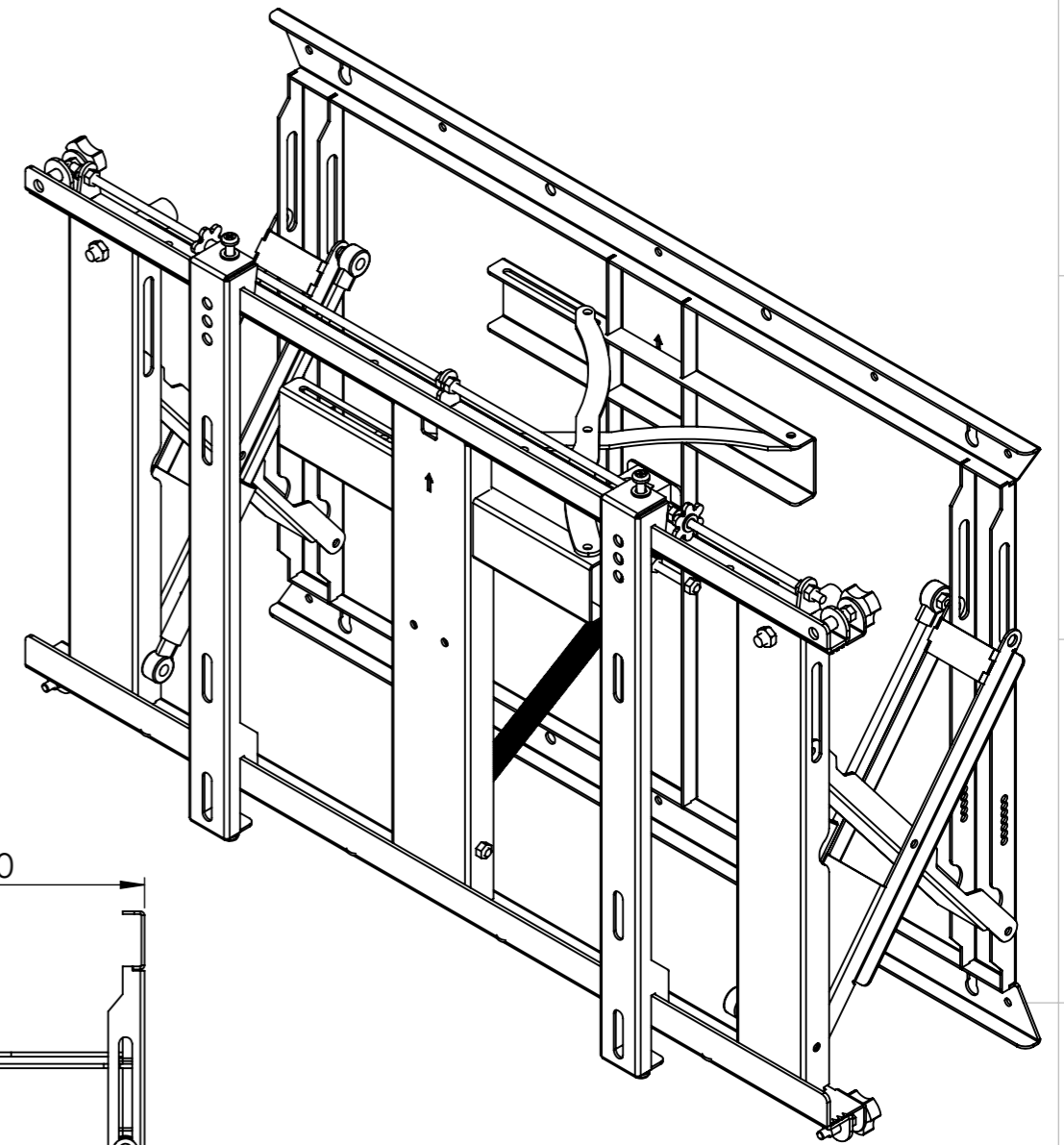
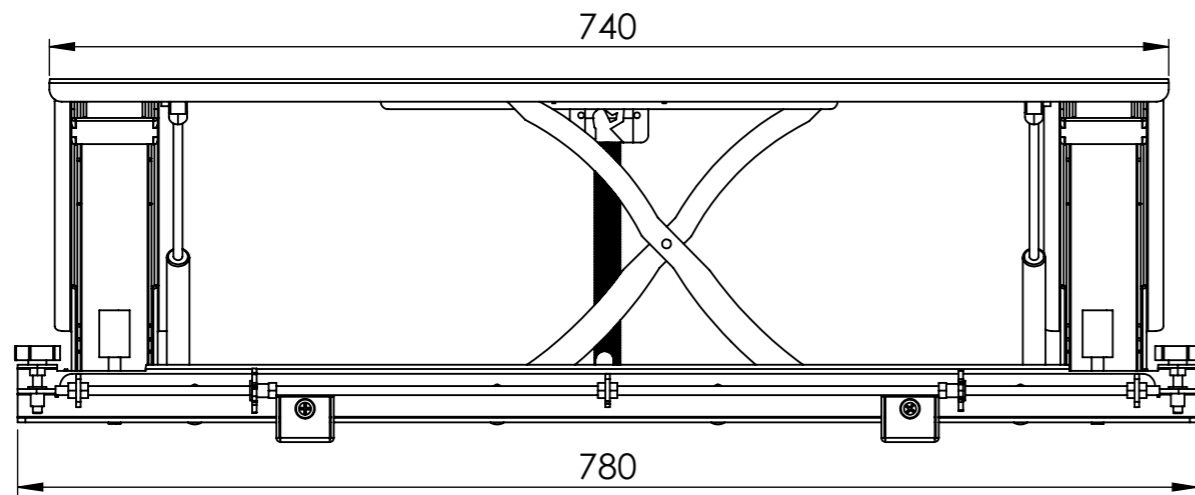

TRAVEL DISTANCE: APPROX. 151MM



PROPRIETARY AND CONFIDENTIAL

THE INFORMATION CONTAINED IN THIS DRAWING IS THE SOLE PROPERTY OF XLT Systems Pte Ltd. ANY REPRODUCTION IN PART OR AS A WHOLE WITHOUT THE WRITTEN PERMISSION OF XLT Systems Pte Ltd IS PROHIBITED.

PROJECT TITLE:

No	REVISION	DATE	NAME

DRAWN BY: YEO 14/07/2023
 CHECKED BY:
 APPROVED BY:
 SCALE 1:5 SHEET : 2/3

CUSTOMER: --

EQUIPMENT / PROJECT NAME

POPOUT VIEW

PART NAME

ASSEMBLY DRAWING

PART NUMBER

POPOUT BRACKET 2023 ASSY

MATERIAL

MS

TREATMENT

BLACK POWDER COAT

QTY

01

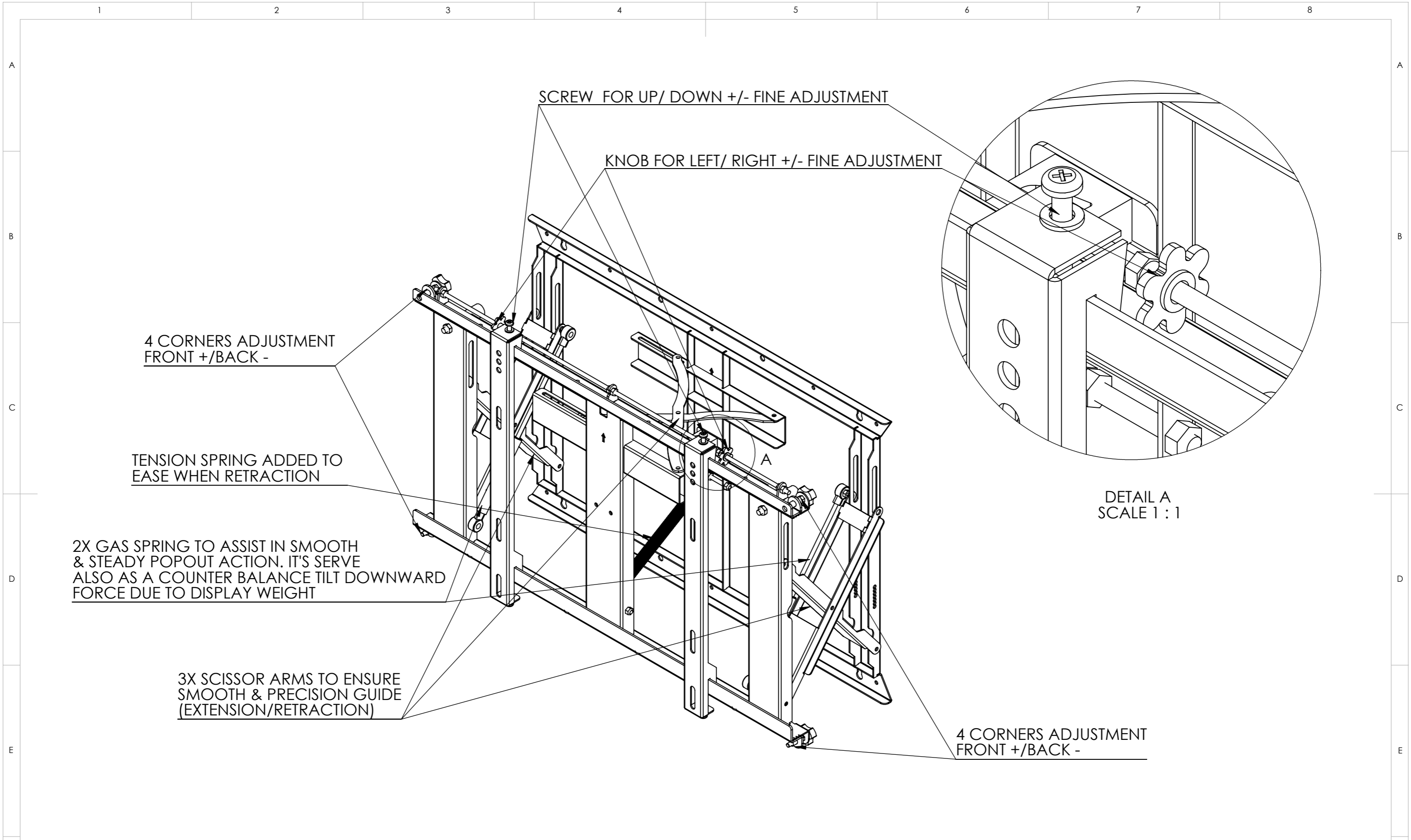

PROPRIETARY AND CONFIDENTIAL
 THE INFORMATION CONTAINED IN THIS DRAWING IS THE SOLE PROPERTY OF XLT Systems Pte Ltd. ANY REPRODUCTION IN PART OR AS A WHOLE WITHOUT THE WRITTEN PERMISSION OF XLT Systems Pte Ltd IS PROHIBITED.

PROJECT TITLE:

CUSTOMER: --

DRAWN BY: YEO 18/07/2023

EQUIPMENT / PROJECT NAME
ISO VIEW WITH DESCRIPTION

MATERIAL MS

CHECKED BY:

PART NAME
ASSEMBLY DRAWING

TREATMENT
BLACK POWDER COAT

APPROVED BY:

SCALE 1:5 SHEET : 3/3

PART NUMBER
POPOUT BRACKET 2023 ASSY

QTY
01

No	REVISION	DATE	NAME