

**PROPRIETARY AND CONFIDENTIAL**  
 THE INFORMATION CONTAINED IN THIS DRAWING IS THE SOLE PROPERTY OF XLT Systems Pte Ltd. ANY REPRODUCTION IN PART OR AS A WHOLE WITHOUT THE WRITTEN PERMISSION OF XLT Systems Pte Ltd IS PROHIBITED.

PROJECT TITLE:					DRAWN BY:  YEO 27/07/2023		CUSTOMER: --	
					CHECKED BY:		EQUIPMENT / PROJECT NAME	
					APPROVED BY:		WL-2655	
					SCALE 1:3 SHEET : 1/2		PART NAME	
							ASSEMBLY DRAWING	
							PART NUMBER	
							WL-2655 ASSY	

MATERIAL		MS
TREATMENT		BLACK POWDER COAT
QTY		01



# WL-2655 INSTALLATION INSTRUCTIONS

NO MOUNTING MATERIAL IS PROVIDED. PLEASE ENGAGE PROFESSIONAL INSTALLER SHOULD YOU DON'T KNOW HOW TO INSTALL OR CALL LOCAL DEALER FOR ASSISTANCE. MAKE SURE THAT THE WALL STRUCTURE CAN SUPPORT AT LEAST FOUR TIMES THE TOTAL WEIGHT OF THE BRACKET WITH THE TV.

SCREW LIST			
ITEM	QUANTITY	DESCRIPTION	
A	2	M6 X 20MM PAN HEAD	
B	2	M6 X 50MM PAN HEAD	

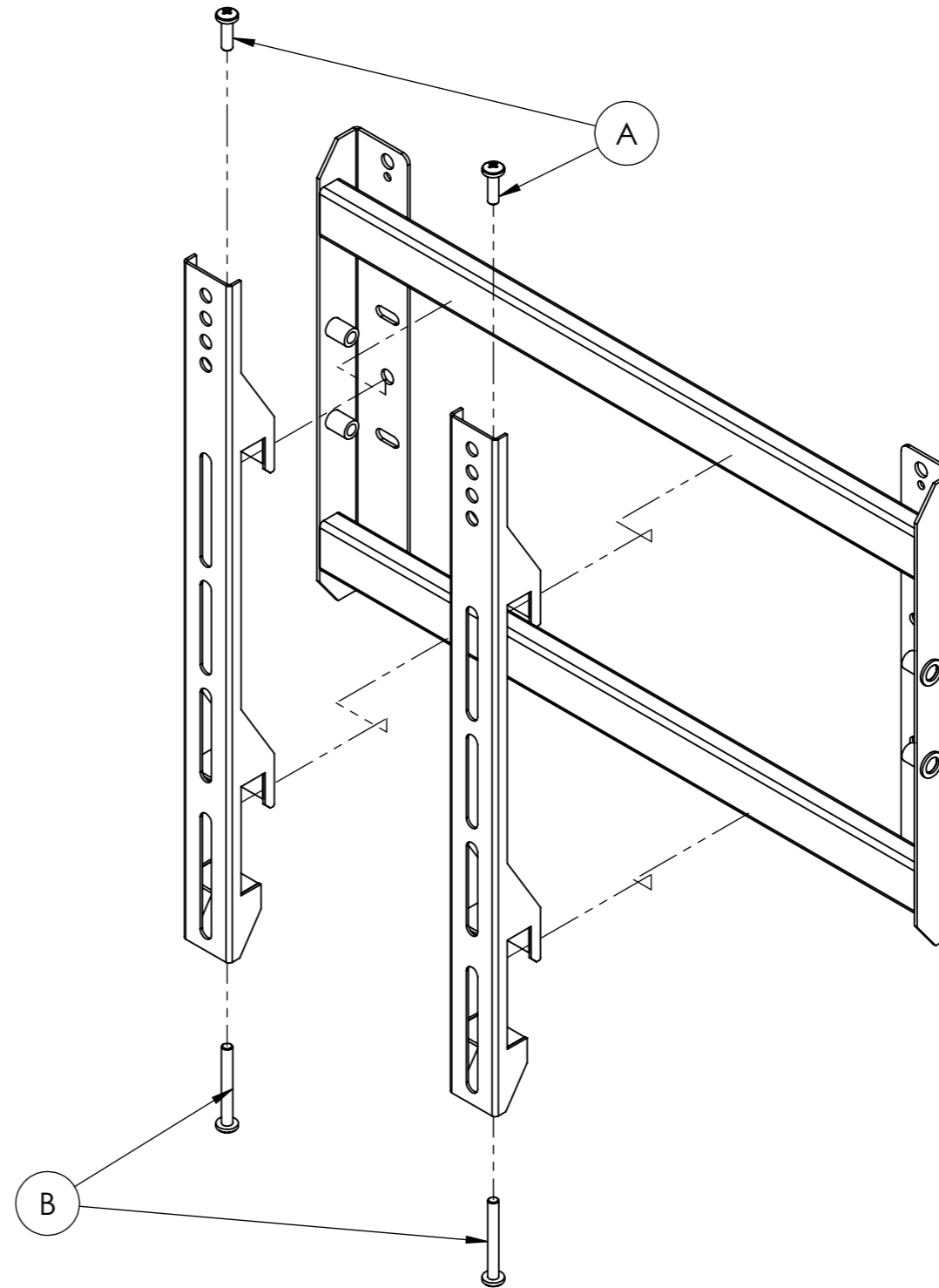

**PROPRIETARY AND CONFIDENTIAL**

THE INFORMATION CONTAINED IN THIS DRAWING IS THE SOLE PROPERTY OF XLT Systems Pte Ltd. ANY REPRODUCTION IN PART OR AS A WHOLE WITHOUT THE WRITTEN PERMISSION OF XLT Systems Pte Ltd IS PROHIBITED.

PROJECT TITLE:

CUSTOMER: --

DRAWN BY: YEO 16/08/2023

CHECKED BY:

APPROVED BY:

EQUIPMENT / PROJECT NAME

WL-2655 INSTALLATION GUIDE

PART NAME

ASSEMBLY DRAWING

PART NUMBER

WL-2655 ASSY

MATERIAL

MS

TREATMENT

BLACK POWDER COAT

QTY

01

No

REVISION

DATE

NAME



SCALE 1:2

SHEET : 2/2